

# JIBBI



Product of the year

PATENT PENDING

# 1250 EVO



CRAWLER TELESCOPIC BOOM

**ALMACRAWLER** 

ALMAC-PACIFIC.COM.AU



# JIBBI 1250 EVO

JIBBI is the new crawler telescopic boom by AlmaCrawler.

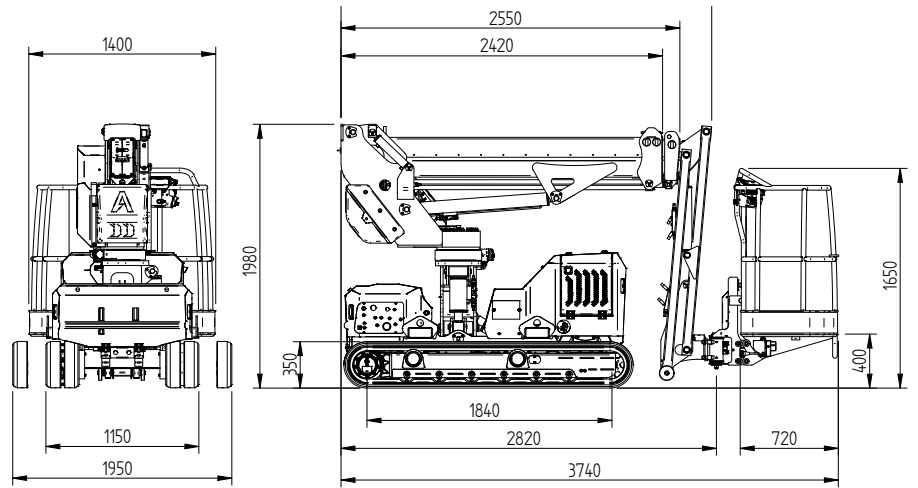

## Patent pending innovations

New Dynamic Work Performance (DWP by Almac)

Undercarriage integrated by new Safe-lock System



Cable remote console by AUTEC

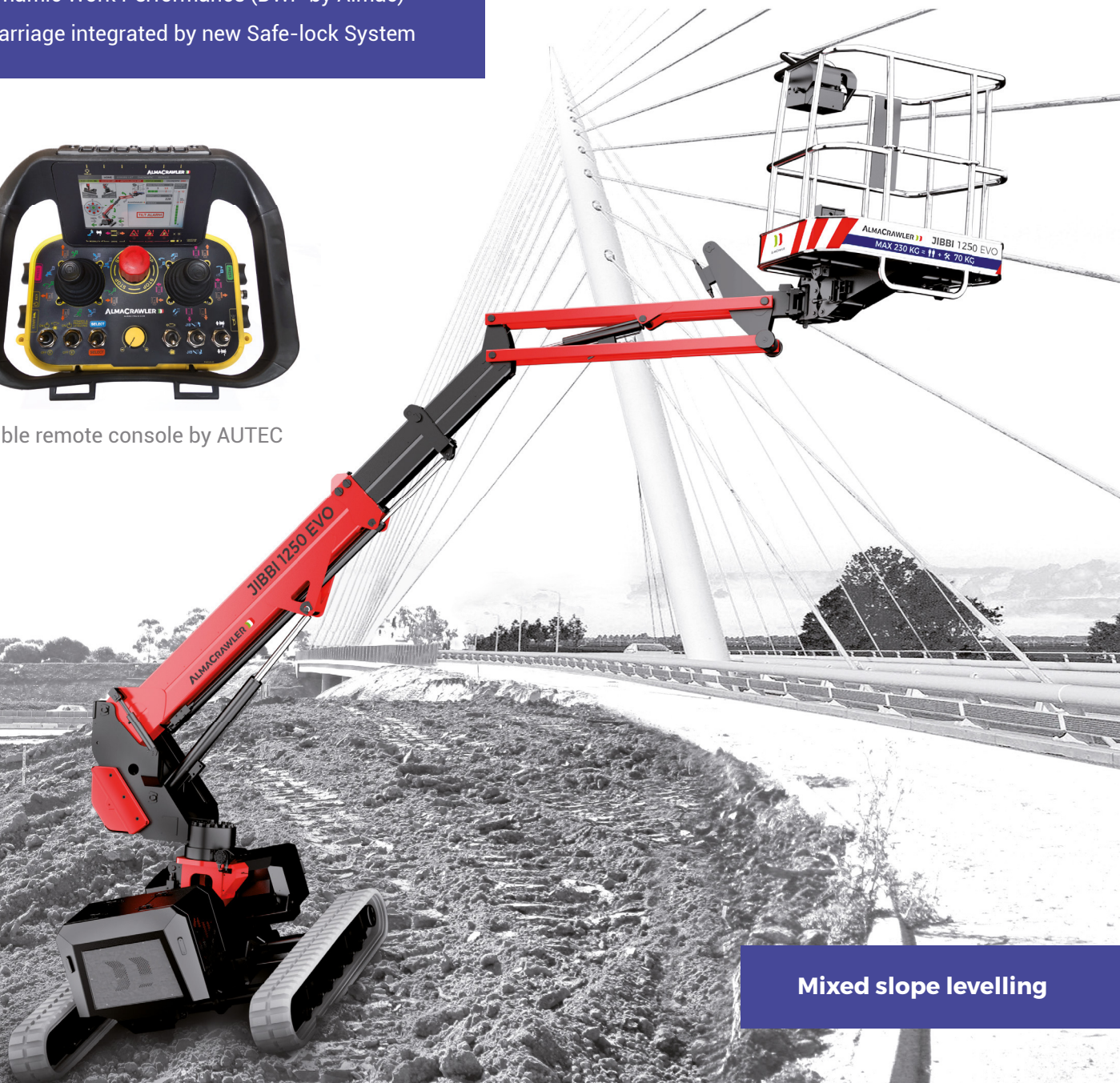

Mixed slope levelling

## Technical data

Max working height	12,2 m
Max height basket floor	10,2 m
Moving height	8,0 m
Max outreach (load 80 kg)	7,0 m
Max outreach (load 230 kg)	5,4 m
Rotation angle	+/- 110°
Basket size	1,4 x 0,7 m
Basket rotation angle	+/- 70°
Max basket capacity	230 kg
Length in stowed position (with detached basket)	3,7 (3,0) m
Min width in stowed position	1,15 m
Max working width	1,95 m
Min height in stowed position	1,98 m
Longitudinal leveling	+/- 15°
Lateral leveling	+/- 15°
Max gradeability	25°
Max side gradeability	25°
Drive speed (fast)	2,5 km/h
Security speed	0,3 km/h

## Weights

Traffic load	3,86 kN/m <sup>2</sup>
Total weight	2850 kg

## Power

3TNM68 -AS Yanmar engine (diesel)	14 kW - 19,2 Hp
-----------------------------------	-----------------

## Extras - On Demand

Non-marking tracks	-
Electric pump 220V-2,2KW / 50Hz	-
Radio remote control	-
Arctic lubricant for cold climate	-

## Features

Yanmar Diesel Engine, 3 Cylinders  
(14,1kW - 19,2 HP)

240° Slewing ring rotation

Basket rotation kit +/- 70°

Integrated Drive System  
(using single joystick)

## Ultrasonic Anti-collision System



## Compact dimensions Removable basket

## Automatic & Dynamic Levelling Pro-Active Levelling





# JIBBI 1250 EVO

12.2m	230kg	19.2Hp	$\pm 15^\circ$	2.5 km/h	$\pm 15^\circ$
MAX. W.H.	CAPACITY	POWER	LONG. LEVEL.	SPEED	LATER. LEVEL.

- 80 kg
- 120 kg
- 230 kg

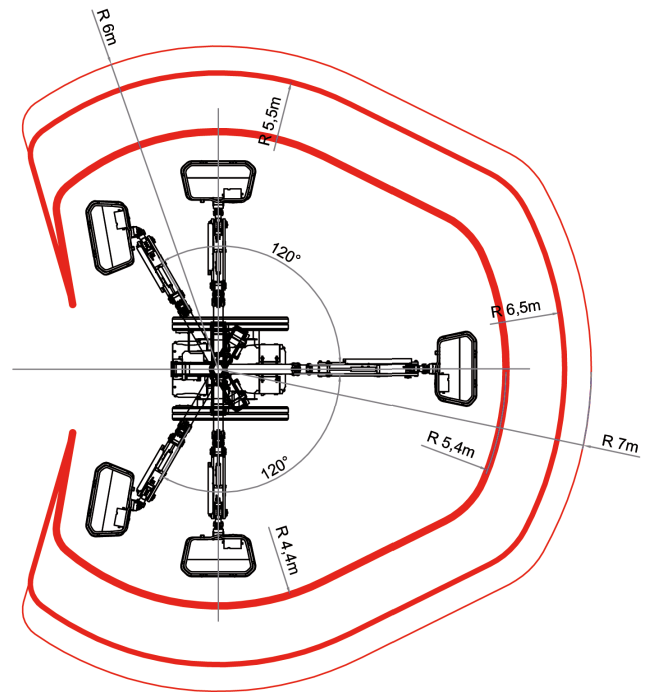
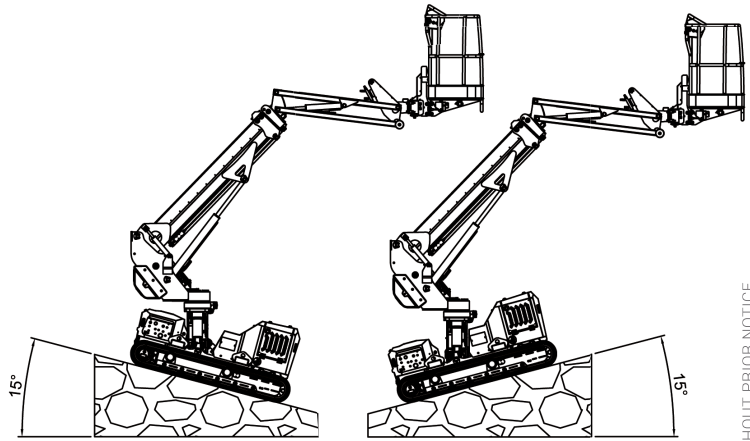
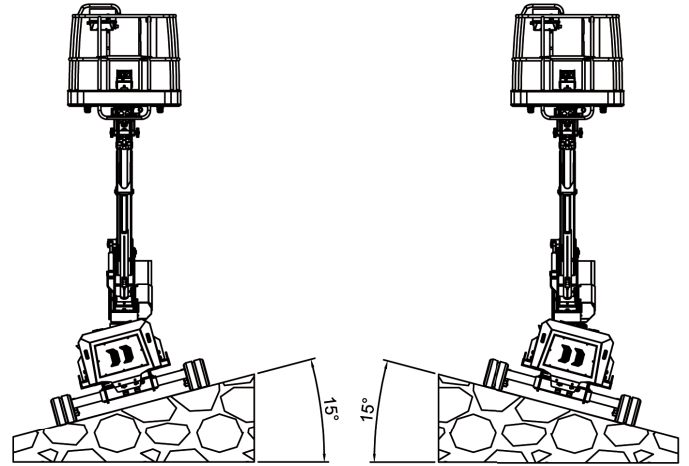
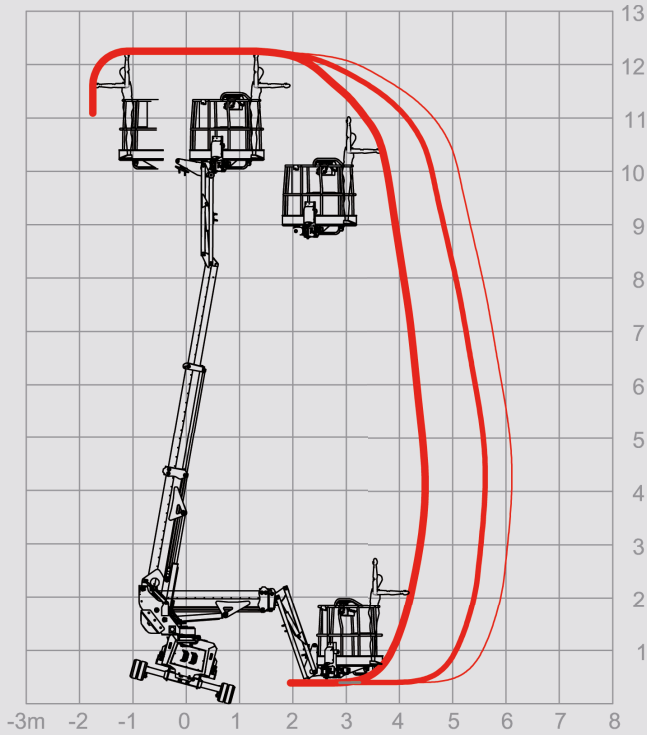
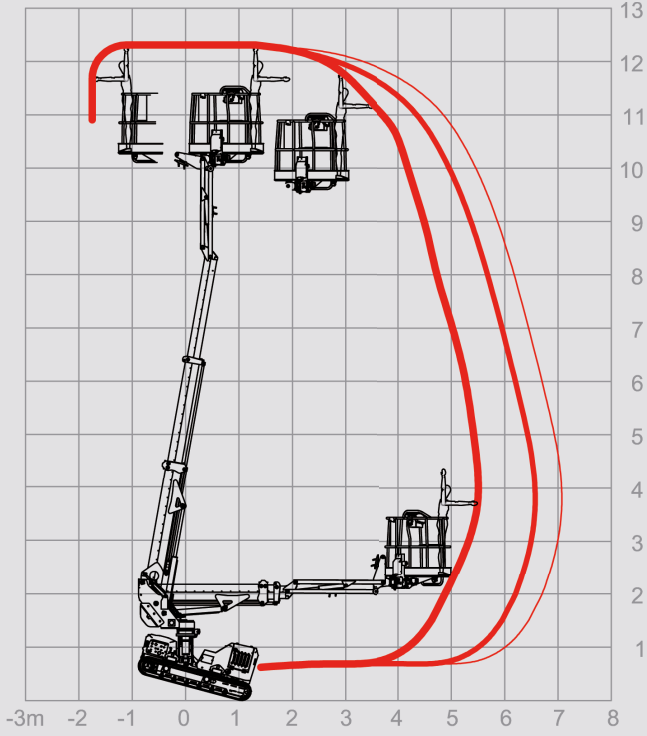

Level 10, 68 Pitt Street, SYDNEY, NSW2000  
 Email [info@almac-pacific.com.au](mailto:info@almac-pacific.com.au)

**ALMACRAWLER**   
 ALMAC-PACIFIC.COM.AU

ALL DATA REPORTED IN THIS CATALOGUE ARE NOT BINDING. ALMAC SRL RESERVES THE RIGHT TO CHANGE SPECIFICATIONS WITHOUT PRIOR NOTICE.